

ASSEMBLY INSTRUCTION

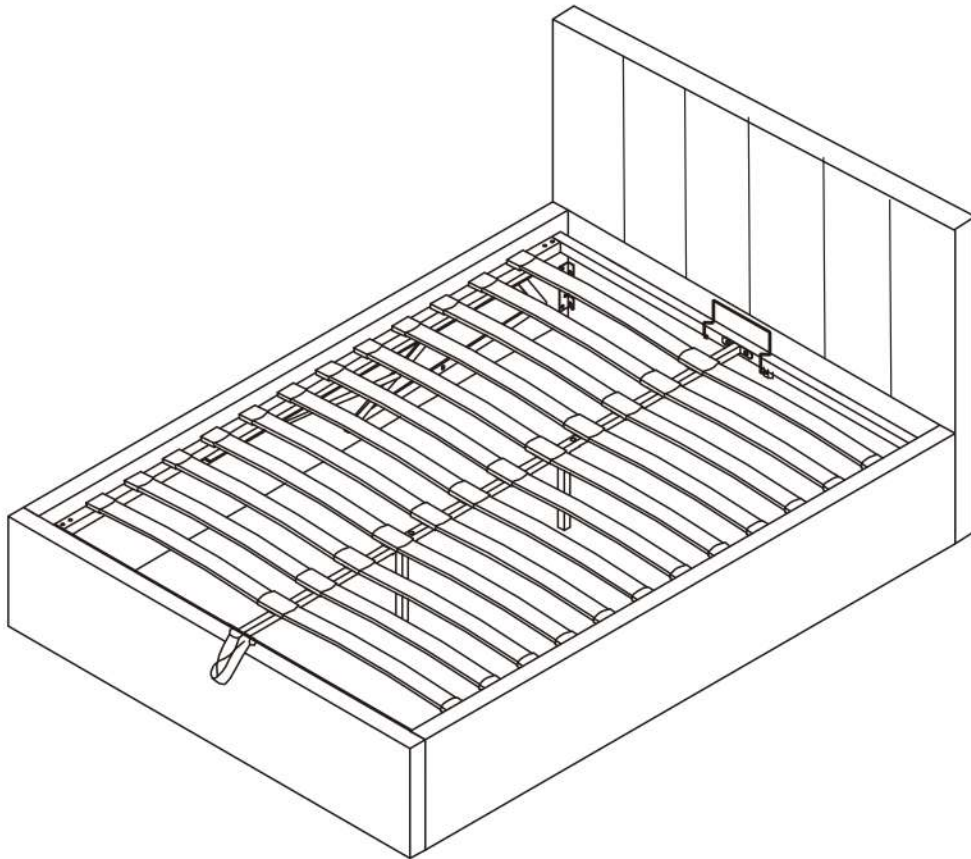

IMPORTANT

PLEASE READ BEFORE YOU CONTINUE FURTHER

THE PRODUCT YOU HAVE PURCHASED WILL GIVE YOU MANY YEARS OF SERVICE IF YOU FOLLOW THE GUIDELINES FOR ITS SAFE ASSEMBLY AND PERIODIC MAINTENANCE AND CLEANING.

DO NOT FOR ANY REASON USE A POWER TOOL TO ASSEMBLE THIS PRODUCT .ITS USE WILL INVALIDATE ANY CLAIM YOU MAY HAVE AND COULD MAKE THIS PRODUCT UNSAFE .







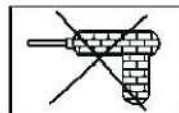

DEPENDING ON THE AMOUNT OF USE THIS PRODUCT RECEIVES IT MAY BE NECESSARY TO TIGHTEN UP THE FIXNGS FROM TIME TO TIME .THIS IS COMPLETELY NORMAL FOR ANY FLAT PACK FURNITURE

FOR CLEANING USE A DAMP CLOTH (NOT WET),DRY DUSTER AND NORMAL FURNITURE POLISH.

USE OF POWER TOOLS TO ASSEMBLE THIS PRODUCT WILL INVALIDATE ANY CLAIM AND MAY DAMAGE THIS PRODUCT MAKING IT UNSAFE.



HARDWARE LIST

REF		HARDWARE NAME	QTY
A		M8*20 BOLT	24 PCS
B			4 PCS
C		M8*45 BOLT	14 PCS
D			1 PC
E		M8 FLAT WASHER	14 PCS
F		NUT	14 PCS
G		ALLEN KEY	1PC
H		OPEN SPANNER	1PC
I			1PC
J			
K			
L			
M			

PART LIST

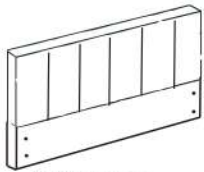

(1) X1PC

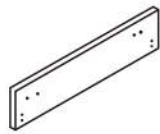

(2) X1PC



(3) X1PC



(4) X1PC



(5) X1PC

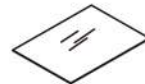

(6) 1PC



(7) X2PCS



(8) X2PCS



(9) X1PC

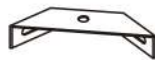

(10) X2PCS



(11) X32PCS



(12) X32PCS



(13) X16PCS



(14) X2PCS



(15) X4PCS

DO NOT USE POWER TOOLS WHEN ASSEMBLING THIS PRODUCT. IT MAY CAUSE DAMAGE TO FASTENERS AND VOID THE WARRANTY.

STEP 1

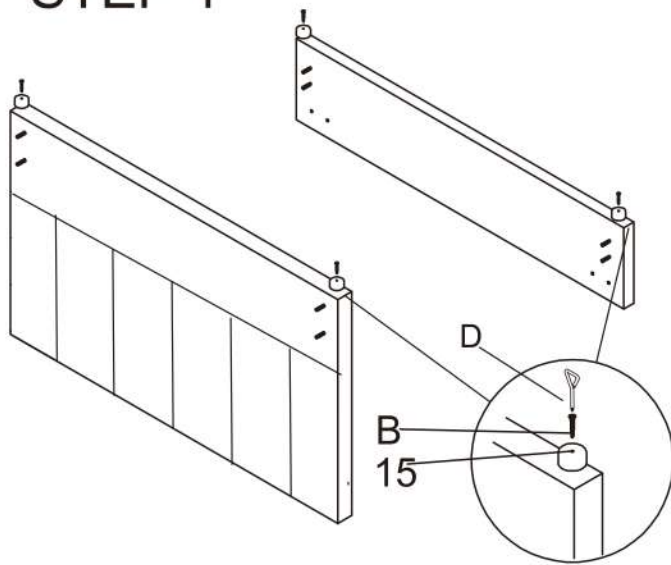

STEP 2

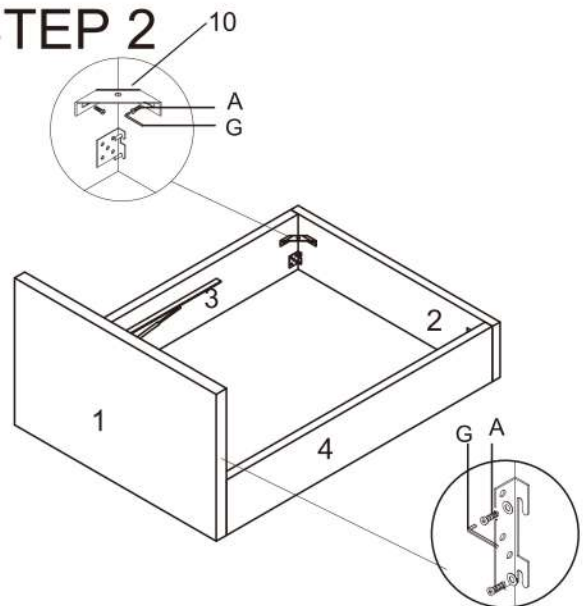

STEP 3

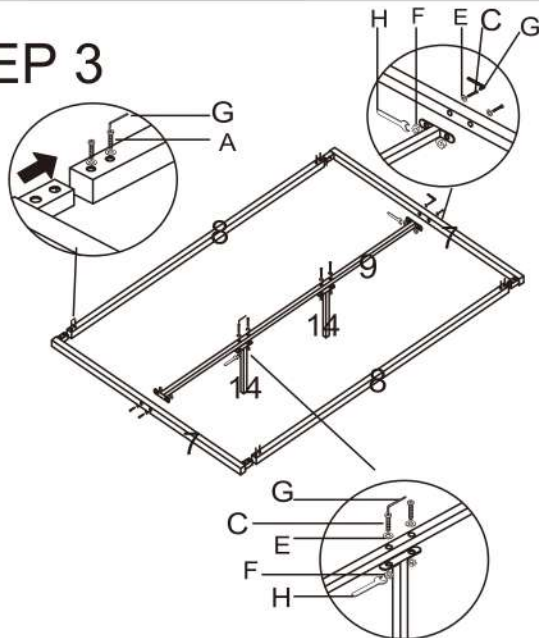

STEP 4

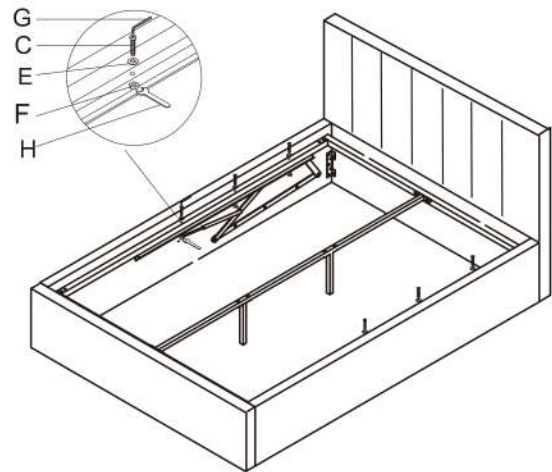

STEP 5

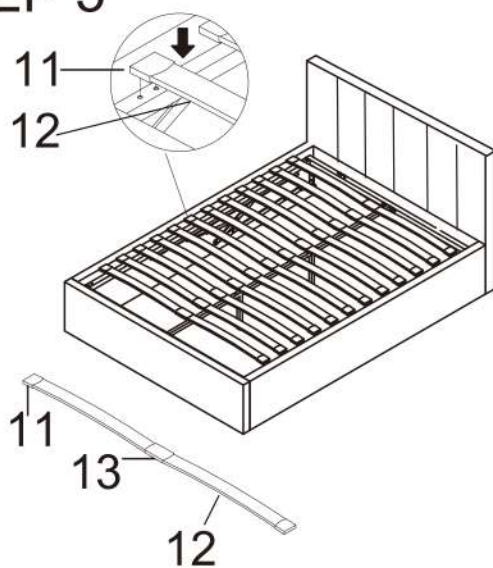

STEP 6

